

14.582 International Trade II  
— Lecture 7: Firm Heterogeneity (Theory II) —

# Announcements

- ① Pset 1 has been posted. It is due on March 12.
- ② Friday's recitation: Refresher on production function estimation.

# Today's Plan

- ① Revisiting New Trade Theory with firm heterogeneity
- ② Looking up: Macro implications of firm heterogeneity
- ③ Looking down: What else do micro-level data say?
- ④ Other firms' organizational decisions

# 1. Revisiting New Trade Theory with Firm Heterogeneity

# Revisiting New Trade Theory with Firm Heterogeneity

## Basic Idea

- Melitz (2003) builds on Krugman (1980)
- Krugman (1980) imposes two strong assumptions:
  - ① **One factor of production**  $\Rightarrow$  no role for factor endowments
  - ② **CES preferences**  $\Rightarrow$  no changes in mark-ups
- We will first discuss extensions of Melitz (2003) that relax these two assumptions by revisiting other classics from the New Trade Theory:
  - ① **Multiple factors of production:** BRS (2007)  
[Melitz (2003) meets Helpman and Krugman (1985)]
  - ② **Linear demand:** Melitz and Ottaviano (2007)  
[Melitz (2003) meets Krugman (1979)]

# Multiple Factors: Bernard, Redding and Schott (2007)

## Summary

- Introduce a second factor of production into Melitz (2003)
- **Goal:**  
Analyze the interaction between inter-industry reallocations—at the core of Heckscher-Ohlin model—and intra-industry reallocations—at the core of Melitz (2003)
- **Insight:**  
Because of differences in export opportunities, intra-industry reallocation differ systematically across comparative advantage and disadvantage sectors

# Multiple Factors: Bernard, Redding and Schott (2007)

## Model

- BRS (2007) consider a world economy with:
  - 2 countries, Home and Foreign
  - 2 industries, 1 and 2
  - 2 factors,  $l$  and  $s$
- Factor endowments across countries are such that

$$\frac{\bar{s}^H}{\bar{l}^H} \geq \frac{\bar{s}^F}{\bar{l}^F}$$

- Production is like in Melitz (2003), but total costs are given by

$$\Gamma_i = \left[ f_i + \frac{q_i}{\varphi} \right] (w_s)^{\beta_i} (w_l)^{1-\beta_i}, \text{ with } \beta_1 > \beta_2$$

# Multiple Factors: Bernard, Redding and Schott (2007)

## Results

- Following the opening up of trade, profits increase more in comparative advantage industries  $\Rightarrow$  productivity cut off and "average" productivity increase more as well
- **Magnification effect** (Proposition 6)  
*The opening of (costly) trade magnifies ex ante cross country differences by inducing endogenous Ricardian productivity differences at the industry level that are positively correlated with H-O based comparative advantage:  $\tilde{\varphi}_1^H / \tilde{\varphi}_2^H \geq \tilde{\varphi}_1^F / \tilde{\varphi}_2^F$ .*
- But remember average productivity  $\neq$  CES aggregate productivity
  - Cut-off and CES aggregate productivity move in opposite direction
  - Burstein and Vogel (2011) offer further discussion



# Variable Mark-ups: Melitz and Ottaviano (2008)

## Summary

- Introduce endogenous mark-ups into Melitz (2003)
- **Goal:**  
Explore the pro-competitive effects of trade in environments with firm-level heterogeneity
- **Compared to Melitz (2003):**  
Use Ottaviano, Tabushi, and Thisse (2002) linear demand system instead of CES

# Variable Mark-ups: Melitz and Ottaviano (2008)

## Model

- Preferences are now represented by

$$U^c = q_0^c + \alpha \int_{\omega \in \Omega} q^c(\omega) d\omega - \frac{1}{2} \gamma \int_{\omega \in \Omega} [q^c(\omega)]^2 d\omega - \frac{1}{2} \eta \left[ \int_{\omega \in \Omega} q^c(\omega) d\omega \right]^2$$

where:

- $q_0$  is consumption of a homogeneous good
- $\alpha > 0, \eta > 0$  reflect substitution between homogeneous and differentiated good
- $\gamma$  reflect substitution across differentiated varieties

# Melitz and Ottaviano (2008)

## Model (Cont.)

- Quadratic preferences lead to a linear demand system:

$$q(\omega) = Lq^c(\omega) = \frac{\alpha L}{\eta N + \gamma} + \frac{\eta N}{\eta N + \gamma} \frac{L}{\gamma} \bar{p} - \frac{L}{\gamma} p(\omega)$$

where:

- $N$  is the number of varieties
- $\bar{p} \equiv \frac{1}{N} \int_{\omega \in \Omega} p(\omega) d\omega$  is the average price
- **Key property:**

$$\left| \frac{\partial \ln q(\omega)}{\partial \ln p(\omega)} \right| = \frac{\frac{L}{\gamma} p(\omega)}{\frac{\alpha L}{\eta N + \gamma} + \frac{\eta N}{\eta N + \gamma} \frac{L}{\gamma} \bar{p} - \frac{L}{\gamma} p(\omega)}$$

- Lower  $\bar{p} \implies$  higher elasticity  $\implies$  lower mark-ups
- Higher  $N \implies$  higher elasticity  $\implies$  lower mark-ups

# Melitz and Ottaviano (2008)

## Results

- Larger markets are associated with:
  - lower average markups and prices
  - bigger and more profitable firms
  - higher welfare
- Compared to Melitz (2003):
  - opening up to trade has pro-competitive effects (as in Krugman 1979)
  - firms select into exporters and non-exporters even in the absence of fixed costs (finite reservation prices)
- Does that imply that gains from trade liberalization are larger than if markups were constant?
  - Arkolakis, Costinot, Donaldson and Rodriguez-Clare (2017) say no
  - Key issue is larger compared to what?
  - We'll come back to that point in subsequent lectures

## 2. Looking Up: Macro Implications of Firm Heterogeneity

# Looking Up: Macro Implications of Firm Heterogeneity

## Basic Idea

- By introducing firm-level heterogeneity, Melitz (2003) was able to explain **micro-level** facts inconsistent with previous theories
- **Question:**  
Does the introduction of firm heterogeneity have further implications at the **macro-level**?
- Next models provide positive answers by showing that:
  - ① Selection of heterogeneous firms into exports matters for **trade volumes**: Chaney (2008), HMR (2008)
  - ② Selection of heterogeneous firms into exports matters for **inequality**: Helpman, Itskhoki and Redding (2010)

# Gravity (I): Chaney (2008)

## Summary

- In Krugman (1980), exports from  $i$  to  $j$  satisfy “**gravity**”:

$$X_{ij} = Cst \times \frac{Y_i Y_j}{(\text{Trade barriers}_{ij})^\sigma}$$

⇒ impact of trade barriers is **higher** in sectors with high  $\sigma$

- In a (version of) Melitz (2003) with Pareto distribution, Chaney (2008) shows that exports satisfy

$$X_{ij} = Cst \times \frac{Y_i Y_j}{(\text{Trade barriers}_{ij})^{\varepsilon(\sigma)}} \text{ with } \varepsilon'(\sigma) < 0$$

⇒ impact of trade barriers is **lower** in sectors with high  $\sigma$

# Gravity (I): Chaney (2008)

## Model

- Start from Melitz (2003) with Pareto distribution and asymmetric countries
- To simplify the analysis (though not crucial, see e.g. Arkolakis, Demidova, Klenow, and Rodriguez-Clare 2008):
  - number of entrants is fixed in each country and industry (no free entry condition)
  - wages are constant across countries (because they all produce the same homogeneous good one-to-one from labor)
- **Trade barriers** between country  $i$  and  $j$  depend on:
  - iceberg trade costs  $\tau_{ij} \geq 1$
  - fixed marketing costs  $f_{ij} \geq 0$



# Gravity (I): Chaney (2008)

## Results

- By definition, bilateral exports from country  $i$  to country  $j$  are equal to

$$X_{ij} = \int_{\varphi_{ij}^*}^{+\infty} r_{ij}(\varphi) g(\varphi) d\varphi$$

where:

- $r_{ij}(\varphi) \equiv R_j (P_j \rho \varphi / \tau_{ij})^{\sigma-1}$  are revenues of firm with productivity  $\varphi$  from country  $i$  selling in country  $j$
  - $r_{ij}(\varphi_{ij}^*) = \sigma f_{ij}$  are the revenues of the “cut-off” firm
- **Basic Idea:**
    - In Krugman (1980), impact of trade barriers only reflects the impact of *variable* trade costs on *revenues per firm* [Intensive margin  $\equiv r_{ij}(\varphi)$ ]
    - With firm-heterogeneity, impact of trade barriers reflect the impact of both *variable* and *fixed* trade costs on *revenues per firm* as well as *total number of firms* [Extensive margin  $\equiv \varphi_{ij}^*$ ]

# Gravity (I): Chaney (2008)

## Results (Cont.)

- Bilateral exports can be rearranged as

$$X_{ij} = \Pr [r_{ij}(\varphi) \geq \sigma f_{ij}] \times E [r_{ij}(\varphi) | r_{ij}(\varphi) \geq \sigma f_{ij}]$$

- Since productivity  $\varphi$  is drawn from a Pareto with shape parameter  $\gamma$ , it is easy to check that

$$\begin{aligned} E [r_{ij}(\varphi) | r_{ij}(\varphi) \geq \sigma f_{ij}] &= Cst \times f_{ij} \\ \Pr [r_{ij}(\varphi) \geq \sigma f_{ij}] &= Cst \times (f_{ij})^{-\frac{\gamma}{\sigma-1}} \times (\tau_{ij})^{-\gamma} \end{aligned}$$

- This implies

$$X_{ij} = \frac{Cst}{(f_{ij})^{\frac{\gamma}{\sigma-1}-1} \times (\tau_{ij})^{\gamma}}$$

- $Cst$  can be expressed as a function of  $Y_i Y_j$  using market clearing

- **The impact of variable trade costs:**

- Compared to Krugman (1980), variable trade costs have no effect on average revenues per firm (if  $\tau_{ij} \nearrow$ , selection of more productive firms into exports exactly offsets the direct  $\searrow$  in revenues per firm)
- Variable trade costs only matter through their impact on the number of firms serving a particular market, which depends on the shape of the productivity distribution  $\gamma$ , *not* the elasticity of substitution  $\sigma$

- **The impact of fixed exporting costs:**

- By contrast, the impact of fixed trade costs *does* depend on the elasticity of substitution  $\sigma$
- If  $\sigma$  is lower, love of variety is higher. Thus,  $\nearrow$  in  $f_{ij}$  that  $\searrow$  number of firms from  $i$  serving  $j$  has higher impact on bilateral sales

# Gravity (I): Chaney (2008)

Aside: connection with Eaton and Kortum (2002)

- As we have seen earlier in 14.581, Eaton and Kortum (2002) have developed a Ricardian model that also leads to a “gravity” equation
- In both models, average revenues per variety are independent of variable trade costs
- As a result, elasticity of bilateral exports with respect to variable trade costs only is a function of productivity parameters
- In both models, the fact that changes in bilateral trade flows only reflect changes in number of varieties exported heavily relies on functional form assumption: Pareto and Frechet, respectively

# Gravity (II): Helpman, Melitz, and Rubinstein (2008)

## Summary

- In Krugman (1980), bilateral exports should always be strictly positive (with finite variable trade costs)
- In the data, we see many zeros
- Like Chaney (2008), Helpman, Melitz, and Rubinstein (2008) start from a Melitz (2003) model with asymmetric countries, but in order to explain zeros in the data they consider *truncated Pareto distributions*
- Under these assumptions, they show that standard estimates of the elasticity of *firm's* revenues with respect to distance will be biased:
  - 1 **Omitted variable bias**
  - 2 **Selection bias**

# Gravity (II): Helpman, Melitz, and Rubinstein (2008)

## Summary (Cont.)

- **Omitted variable bias** can be understood as follows:
  - Changes in bilateral trade flows also reflect changes in number of exporting firms. Since number of exporting firms is negatively correlated with trade costs, this induces upward bias
  - This is related to Chaney's observation that elasticity of trade flows with respect to variable trade costs is not equal to the elasticity of substitution, but the shape parameter of the Pareto  $\gamma > \sigma - 1$
- **Selection bias** can be understood as follows:
  - Sample of non-zero trade flows is not a random sample of trade flows. In this sample, unobserved component of trade costs tends to be lower for countries further away, which induces downward bias.
- **Contribution:**
  - Show how to correct for two sources of biases using a two-stage estimation procedure [as discussed in Dave's lecture]
  - First source of bias is important. Second not so much.
  - If interested in difference between  $\gamma$  and  $\sigma$ , why not use firm-level data?

# Inequality: Helpman, Itskhoki, and Redding (2010)

## Summary

- In Melitz (2003), opening up to trade tends to make distribution of firms' revenues more unequal
- **Central idea of HIR (2010):**  
If workers' wages are positively correlated with firms' revenues, then opening up to trade tends to increase wage inequality
- **Contribution:**
  - Provide micro-foundations to generate correlation between firms' wages and revenues in a general equilibrium model
  - In addition, model is consistent with many micro-level facts (e.g. larger firms and exporters pay higher wages)

# Inequality: Helpman, Itskhoki, and Redding (2010)

## Model

- Model builds on Helpman and Itskhoki (2009) which combines
  - 1 Melitz firm heterogeneity
  - 2 Diamond-Mortensen-Pissarides search frictions
  - 3 Stole and Zwiebel wage bargaining
- HI generate a rich set of predictions about trade and unemployment
  - *but none about inequality: constant revenue/worker  $\Rightarrow$  constant wages*
- **Key addition:**
  - 1 Unobserved worker heterogeneity
  - 2 Endogenous screening technology
- HIR (2010) maintain the tractability of HI (2010)
  - *but add rich set of predictions about inequality: more productive firms screen more  $\Rightarrow$  higher revenue/worker and higher wages*



# Inequality: Helpman, Itskhoki, and Redding (2010)

## Main results

- **Two key predictions:**

- ① Opening up to trade increases wage inequality
- ② A gradual decrease in trade costs first increases and later decreases wage inequality

- **Intuition:**

- Distribution of firms' revenues is more unequal if only *some* firms export
- Under autarky and free trade, either *all* firms are domestic producers or *all* firms are exporters
- Helpman, Itskhoki, Muendler and Redding (2017) add heterogeneity in screening costs and fixed exporting costs and structurally estimate the model using matched employer-employee data from Brazil

### 3. Looking Down: What Else Do Micro-Level Data Say?

# Looking Down: What Else Do Micro-Level Data Say?

## Basic Idea

- **Quantitative models:**

- Melitz (2003) offers a model *qualitatively* consistent with firm-level data, but model is too stylized to explain these data *quantitatively*
- Arkolakis (2010), Eaton, Kortum, and Kramarz (2011) propose variations of Melitz (2003) with richer specification of trade costs to match richness of *firm-level* data

- **New micro-level data:**

- Melitz (2003) focuses on firm-level data, but we now have information about *products* (even shipments)
- Bernard, Redding and Schott (2011), Arkolakis, Ganapati, and Muendler (2015) develop variations of Melitz (2003) to explain—qualitatively or quantitatively—these new product-level facts
- Mayer, Melitz and Ottaviano (2014) propose a similar exercise starting from Melitz and Ottaviano (2008)

# Marketing Costs and Exporter Size: Arkolakis (2010)

## Summary

- Melitz (2003) introduces fixed exporting costs in order to explain why large firms export whereas small firms don't
- In the data, however, we observe that:
  - only a small number of firms export, which suggests that fixed exporting costs are large
  - many exporters only export small amounts, which suggests that exporting costs are small
- Arkolakis (2010) develops a variation of Chaney (2008) with endogenous marketing costs to explain size distribution of exporters

# Marketing Costs and Exporter Size: Arkolakis (2010)

## Model

- Basic environment is the same as in Chaney (2008)
- **Key difference:**
  - In order to reach consumers with probability  $x$  in country  $j$ , a firm from country  $i$  must now pay a fixed cost equal to

$$f_{ij}(x) = f_{ij} \times \left[ \frac{1 - (1 - x)^{1-\mu}}{1 - \mu} \right].$$

- Chaney (2008) corresponds to the particular case in which  $\mu = 0$
- If  $\mu = 0$ , marginal cost of reaching additional consumer is constant and firms find it optimal to reach every potential consumer or none at all.

# Marketing Costs and Exporter Size: Arkolakis (2010)

## Results

- In equilibrium, smaller exporters spend less on fixed marketing costs
  - This explains why a large number of firms export small amounts
- In addition, the model predicts that smaller exporters grow faster after a particular decrease in trade cost
- Nevertheless, **macro-implications** remain the same as in Chaney:
  - Elasticity of aggregate trade flows with respect to variable trade costs is still given by shape parameter of the Pareto
  - Welfare implications are the same as well (more on that later)

# Multi-Product Firms: Bernard, Redding and Schott (2011)

## Summary

- In Melitz (2003), reallocations occur within an industry **across firms**
- In the data, reallocations also occur within firms **across products**
- BRS (2011) develop multi-product variation of Melitz (2003):
  - varieties are reinterpreted as “products” rather than “firms”
  - productivity draws are positively correlated across products within firms
- Model can explain increases in firm-level productivity after trade liberalization (due to selection of most productive products)
  - Even in Melitz (2003), though, *measured* productivity, defined as revenue per worker, increases with firm-level employment
  - Since firm-level employment changes with trade liberalization in Melitz (2003), measured productivity must change as well

## 4. Other Firms' Organizational Decisions



# Other Firms' Organizational Decisions

## Basic Idea

- In Melitz (2003), heterogeneous firms can self-select into two “**organizational forms**”: (i) domestic production; or (ii) export
- In practice, firms engaged internationally face a much larger set of choices. For example:
  - ① They can produce and sell in the Foreign country [*Horizontal FDI*]
  - ② They can also split their production process in two different countries [*Vertical FDI*]. In this case, they can either own their intermediate suppliers or trade at arm's length.
- Helpman, Melitz, and Yeaple (2004) focus on the first choice, whereas Antras and Helpman (2004) focus on the latter

# Horizontal FDI: Helpman, Melitz and Yeaple (2004)

## Model

- Firm productivity  $\varphi$  is drawn from a Pareto,  $G(\varphi) = 1 - \left(\frac{\varphi}{\underline{\varphi}}\right)^k$
- Firm in country  $i$  chooses whether to become domestic producers ( $D$ ) or to serve country  $j$  via exports ( $X$ ) or FDI ( $I$ ).
- Foreign revenues are given by  $r_O(\varphi) = (\varphi/\tau_O)^{\sigma-1} B$ , with  $O \in \{D, X, I\}$
- Variable transport costs satisfy:  $\tau_I^{1-\sigma} = 1 > \tau_X^{1-\sigma} > \tau_D^{1-\sigma} = 0$
- Fixed transport costs satisfy:  $f_I > f_X > f_D$

# Horizontal FDI: Helpman, Melitz and Yeaple (2004)

## Selection into exports and FDI

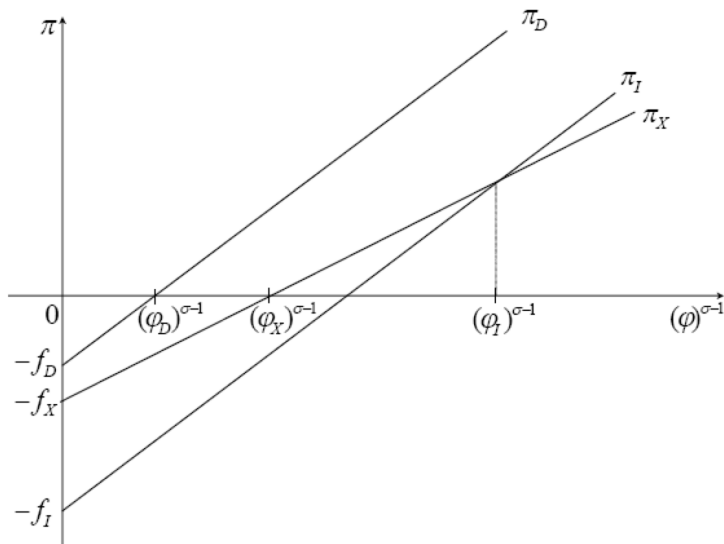

# Horizontal FDI: Helpman, Melitz and Yeaple (2004)

## Main result

- Industries with higher dispersion of productivity across firms—i.e. a lower shape parameter  $k$ —should have a higher ratio of FDI versus export sales (for which they find support in the data)
- **Intuition:**
  - Low- $k$  sectors have relatively more high- $\varphi$  firms
  - high- $\varphi$  firms are more likely to select in  $I$  than  $X$
- **Formally:**

$g$  is log-supermodular in  $\varphi$  and  $-k$ ;  $r$  is supermodular in  $\varphi$  and  $\tau^{1-\sigma}$ ; and log-supermodularity is preserved by integration (Costinot 2009)

# Global Sourcing: Antras and Helpman (2004)

## Model

- Firm productivity  $\varphi$  is drawn from a Pareto,  $G(\varphi) = 1 - \left(\frac{\varphi}{\underline{\varphi}}\right)^k$
- Firm chooses ownership structure, vertical integration ( $V$ ) or outsourcing ( $O$ ), and location of production, North ( $N$ ) or South ( $S$ )
- Authors provide micro-foundations (which we will come back to) s.t:
  - Profits are given by  $\pi_k^l = \chi^{(\mu-\alpha)/(1-\alpha)} \varphi^{\alpha/(1-\alpha)} \psi_k^l - w^N f_k^l$ , with  $(k, l) \in \{V, O\} \times \{N, S\}$
  - Variable organizational costs satisfy:  $\psi_V^S > \psi_0^S > \psi_V^N > \psi_0^N$
- Fixed organizational costs satisfy:  $f_V^S > f_0^S > f_V^N > f_0^N$

# Global Sourcing: Antras and Helpman (2004)

## Selection into organizations

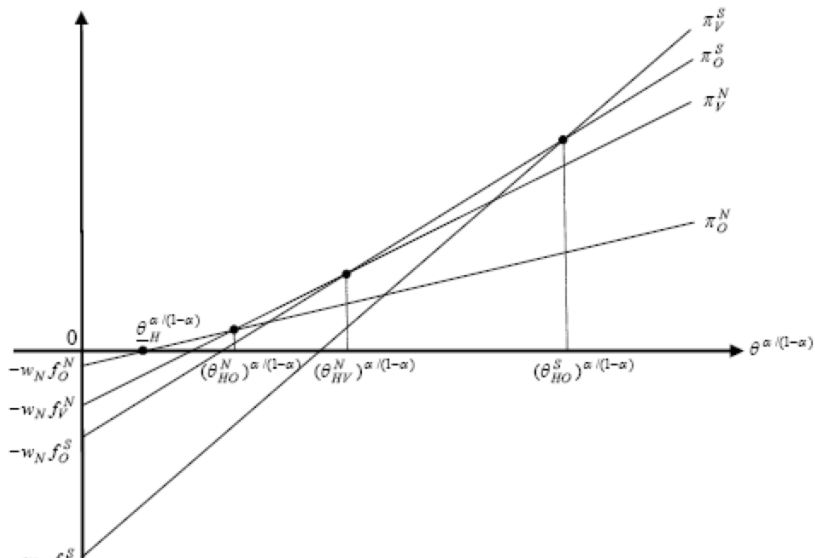

# Global Sourcing: Antras and Helpman (2004)

## Sample of results

- Industries with higher dispersion of productivity across firms—i.e. a lower shape parameter  $k$ —should have:
  - a lower fraction of firms that outsource in the North
  - a higher fraction of firms that insource in the South
  - more offshoring
  - more vertical integration
- Though micro-foundations are different, intuition is similar to results in Helpman, Melitz, and Yeaple (2004)

# More Items on the Agenda

- Quality versus productivity (e.g. Verhoogen 2008)
- Zeros (e.g. Eaton, Kortum, Sotelo 2012)
- Volatility (e.g. di Giovanni and Levchenko 2012, di Giovanni, Levchenko, and Mejean 2014)
- Heterogeneous importers (e.g. Blaum, Lelarge, Peters 2017)
- Firm-to-firm trade (e.g. Eaton, Kortum, and Kramarz 20XX)
- Quantitative multinational models (e.g. Antras, Tintelnot, Fort 2017, Arkolakis, Ramondo, Rodriguez-Clare , Yeaple 2017, Tintelnot 2017)
- Growth (e.g. Sampson 2016)
- Trade policy (e.g. Costinot, Rodriguez-Clare, and Werning 2016)
- Dynamics (next lecture)